



Air conditioning and chillers

Customized heat transfer solutions



Heat transfer solutions that will help you break barriers

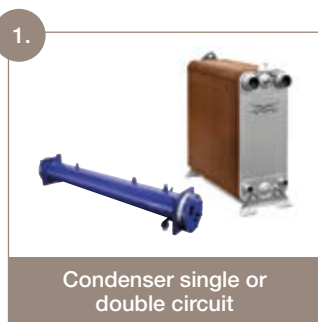

Heat exchangers can serve many different purposes in a chiller. These are the most common:

- *Evaporator* – providing the cooling effect between the refrigerant and the water/brine.
- *Condenser* – enabling the condensation of the refrigerant by rejecting heat to another media. In an air-cooled chiller this media is air; in a water-cooled chiller it is a liquid.
- *Economizer* – increasing the enthalpy effect by boosting sub-cooling in the condensed refrigerant. This increases overall system efficiency.
- *Desuperheater* – recovering the heat from the super-heated refrigerant gas at the compressor outlet.
- *Compressor oil cooler* – Screw or centrifugal compressors may require cooling to increase lifetime and/or efficiency. It can be a refrigerant-to-oil or water-to-oil heat exchanger.

Basics about air conditioning and chillers

The purpose of a chiller is to produce cold water or brine, which is transferred to the ambient or to a process – either directly or through a distribution unit. Cooling is normally achieved through a compressor-driven refrigeration cycle. Chiller systems use various types of refrigerants and compressors – the following being the most common:

- *Scroll compressors*: small to medium-sized chillers (can also be configured in multiple-scroll series)
- *Screw compressors*: medium-sized to large chillers
- *Centrifugal compressors*: large to very large chillers
- Absorption chillers are compressor-free

In addition to the type and size of compressor, chillers can also be categorized according to the heat-rejection method. *Air-cooled chillers* use air coils as the condenser, from which the heat is vented to the ambient. For this reason, air-cooled chillers have a larger footprint than water-cooled chillers of similar specifications. *Water-cooled chillers* reject the heat from the condenser into a water circuit. Here, the heat can be recovered and used for heating purposes. It can also be released to the ambient, using for example cooling towers or liquid coolers.

Three innovations that break barriers

OIL COOLERS

Large chillers may require oil coolers for the compressors. BHEs provide an efficient solution, with the added benefit of compactness and a reduced pressure drop. Low pressure drops on the oil side is a key factor in this application, and Alfa Laval's range of low-theta plates is therefore a good solution.

GASKETED PLATE HEAT EXCHANGER, SHELL & TUBE HEAT EXCHANGER AND AIR HEAT EXCHANGER RANGES

In order to provide our customers with a full range of products, Alfa Laval also develops and delivers gasketed plate heat exchangers, shell & tube heat exchangers and air heat exchangers. The industry's most comprehensive range of gasketed plate heat exchangers is available for both cooling and heating duties to complement the entire system. Tubular heat exchangers for air and process conditioning duties, with patented distribution system and dedicated design for respectively positive or negative temperatures. We cover all dry expansion duties up to 2000 kW. Air Cooled Condensers and Liquid Coolers for water cooled chillers, comprise a part of air heat exchanger range, designed for a variety of refrigerants and a variety of ambient conditions.

INNOVATIVE SOLUTIONS / CAPACITY

AC1000 is the largest dual circuit brazed heat exchanger on the market boasting design features that let you increase capacity, lower total system cost and boost efficiency.

AC900 is a new large single circuit heat exchanger optimized for low density refrigerants, designed to increase capacity and lower total system cost.



DYNASTATIC DESIGN / FLEXIBILITY

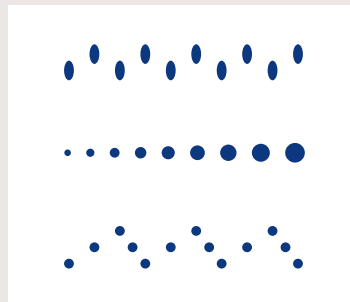

This breakthrough production method gives you complete freedom to design the perfect refrigerant distribution system for your products. Whatever placement, size and number of distributors you want, we can produce it.

FLEXFLOW DESIGN / EFFICIENCY

Our range of asymmetrical flow patterns unlock new levels of efficiency. We don't believe in a one size fits all approach – we develop new asymmetrical patterns tailored by application. The asymmetrical flow patterns allows for smaller refrigerant volumes and optimised water pressure drops.

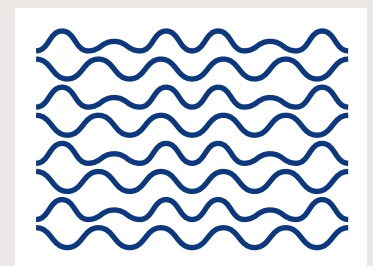

The Alfa Laval advantage

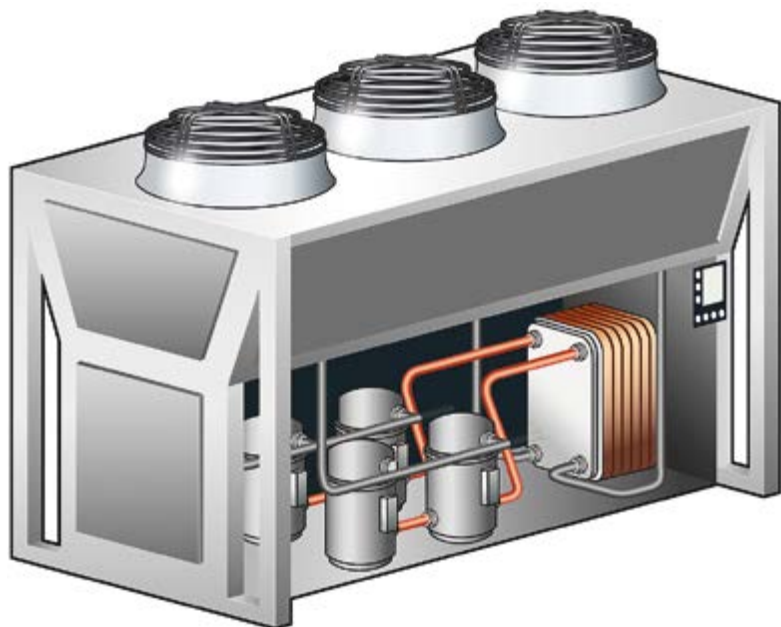

Alfa Laval offers a complete range of heat exchangers – brazed heat exchangers (BHE), shell-and-tube heat exchangers (S&T) and air heat exchangers (AHE). BHEs are very compact compared to any other heat exchanger for similar applications. This means less refrigerant is needed.

All BHE units are pressure-tested and labelled to comply with all major industry approvals (PED, UL, Chinese PV, KHK, KRA, and CRN). They are also leak-tested with helium to ensure that every unit is gas tight.

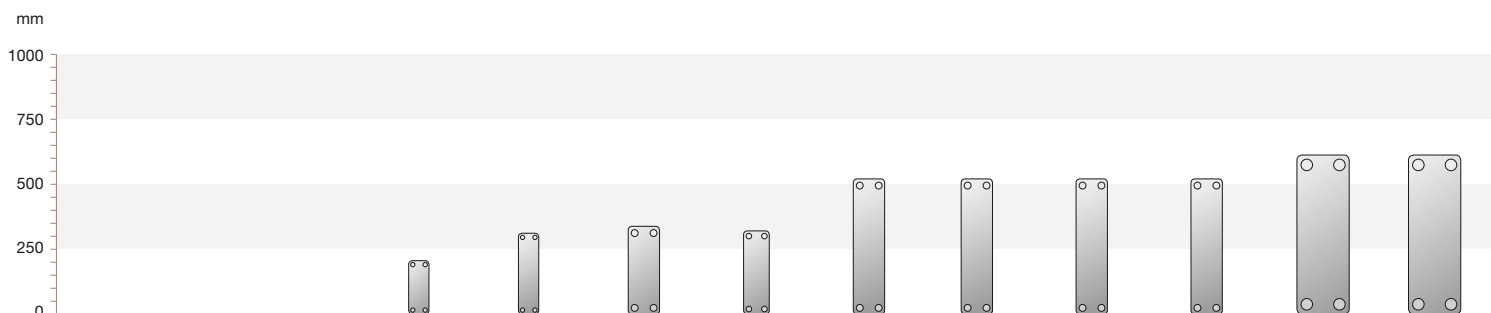

Air Conditioning

	AC16	AC18	CB30	AC30	AC70	CB60	AC72	AC73	AC112	CB110
Evaporator	x	x		x	x	x	x	x	x	
Condenser	x	x	x	x	x	x	x	x	x	x
Economizer	x	x		x	x	x				
Oil cooler		x	x			x				x
Desuperheater		x	x			x				x
Dimensions, mm (width/height)	73.5/209.5	73.5/315.5	113/313	95/325	111/526	113/527	113/529	113/529	191/616	191/616
Design Pressure (BAR)	32/45	32/45	32/45	32/45	32/45	32/45	32/48	32/48	32/48	32/48
Design Pressure (PSI)	464/653	464/653	464/653	464/653	464/653	464/653	464/696	464/696	464/696	464/696
Single or Dual Circuit	Single	Single	Single	Single	Single	Single	Single	Single	Single	Single
Distribution System**			(x)	x	x	(x)	x	x	(x)	
DynaStatic Distribution								x		
Asymmetric plates available	x	x					x	x	x	
High Theta plates available	x	x	x	x	x	x	x	x	x	x
Low Theta plates available			x		x	x			x	x
Combination High & Low			x		x	x			x	x
High Efficiency							x	x	x	

** (x) = optional

Advantage

All relevant approvals are also available for air heat exchangers and shell-and-tube heat exchangers.

For OEM customers, Alfa Laval can optimize the BHE according to specific applications and system requirements. Each optimized heat exchanger is unique to the customer, with a unique article number. Customers can be safe in the knowledge that Alfa Laval uses all its know-how to optimize their products.

Continuous innovation and product development are ensured by Alfa Laval's in-house laboratory. All developments and solutions are validated before being offered to customers.

Product scope

EVAPORATORS

The main focus of Alfa Laval's heat exchangers in chillers is on the evaporator. This function is critical to the performance of the entire chiller. Alfa Laval offers BHEs with different distribution systems and channel plates to

optimize the performance of the unit for the customer's application and operating conditions. Alfa Laval also offers S&T evaporators. The in-depth knowledge of both technologies allows Alfa Laval to find the optimal solution for each customer.

CONDENSERS

All BHE evaporators can operate in reversible mode – in other words as condensers. Optimized condensers are available for water-cooled chillers. To minimize the footprint, the condenser has the same aspect ratio as the evaporator. Performance is further optimized by using different corrugation angles, pressing depths and asymmetric plate channels. Alfa Laval also offers a full range of S&T condensers, for applications or environments where water quality is poor or uncertain.

ECONOMIZERS/SUBCOOLERS

For large screw or centrifugal chillers, Alfa Laval offers BHE units designed as evaporators, with the option of other material specifications and with or without a distribution system, depending on pressure-drop requirements.

DESUPERHEATER

Alfa Laval offers BHE units with very low pressure drops to control the refrigerant circuit and avoid negative effects on the condensing pressure. Generally, these units are designed with large ports and smaller theta angles. Shell-and-tube heat exchangers are also a valid alternative for this purpose. They are able to handle larger volumes and allow heat to be recovered on the condensing side.

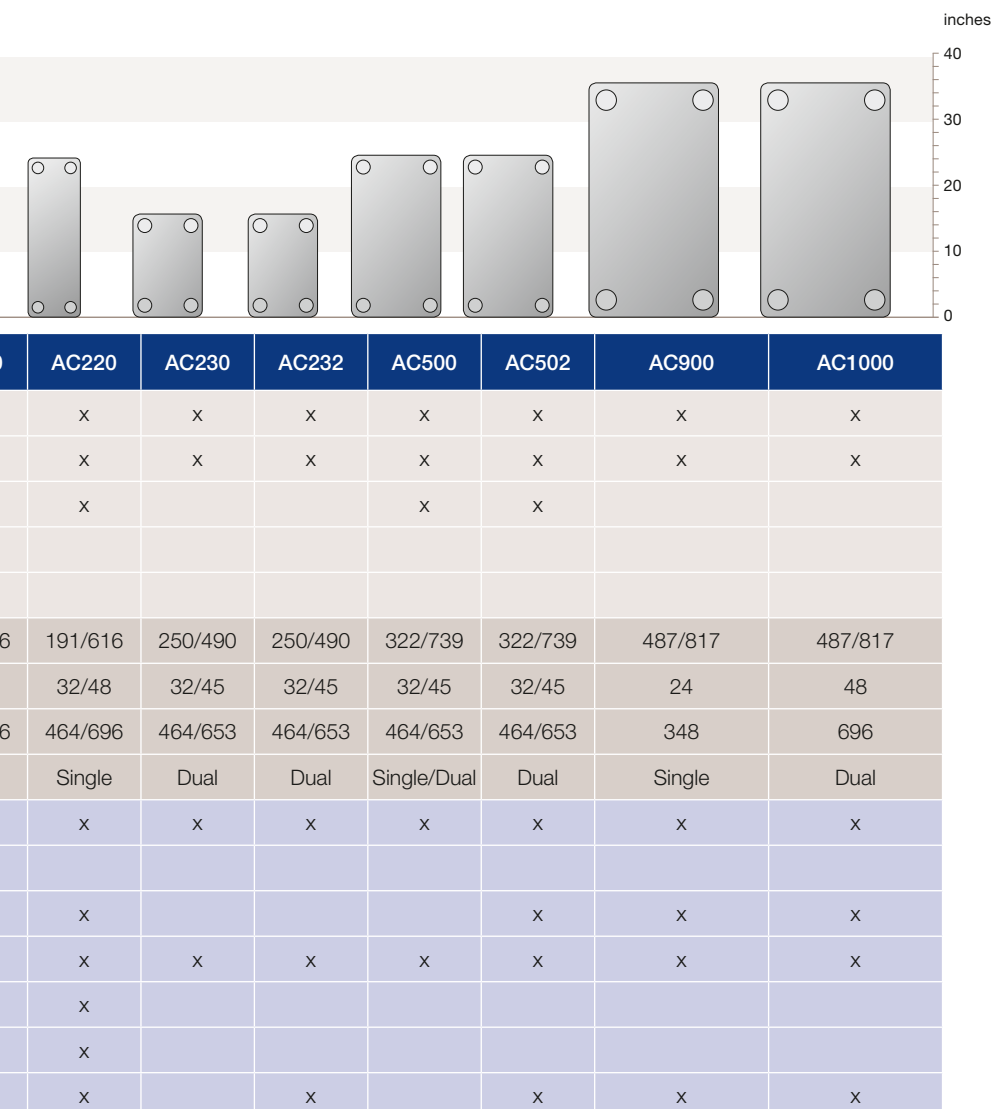



Partner with Alfa Laval to become best in class

With our unique wealth of experience, our dedication to finding innovative new heat transfer OEM solutions with greater efficiency and lower energy consumption and our global manufacturing and distribution network, Alfa Laval is your ideal partner.

Don't get left behind in a competitive market, affected by a constant flow of new regulations and ever-changing trends. We support your need to drive performance to new levels as well as the need of cost-efficient solutions.

Join forces with Alfa Laval and be the best that you possibly can.

OEM applications

- Air Conditioning (Chillers, Absorption Chillers and VRF's)
- Heat Pumps
- Boilers
- Solar Heating
- Domestic Water Heating
- Domestic Hot Water
- Process Cooling
- Fuel Cells
- (Micro) Combined Heating and Power
- Air Dryers
- Air Compressors
- Oil Cooling
- Transport Refrigeration
- Wind Power
- Vending Machines
- Engine cooling (oil, air, lube)
- Engine oil and fuel filtration
- Transmission Oil Cooling
- Hydraulic oil cooling
- Heat recovery

How to contact Alfa Laval

Up-to-date Alfa Laval contact details for all countries are always available on our website at www.alfalaval.com